



Sonic Sens

Ultrasonic Sensor

The SonicSens ultrasonic sensor is ideal for measuring water level, as part of a remote monitoring/telemetry system.

Using an ultrasonic pulse to measure level, the device is not in contact with its environment. This stops the unit from becoming contaminated and lowers maintenance requirements. It is also low power, allowing it to operate for extended periods of time.

When combined with an Intelligens logger, the combination of non-contact, low power and remote telemetry make the SonicSens ideal for remote or challenging installations.



Key Features and Benefits

- **Intelligent sensor:** Compatible with the advanced Intelligens telemetry data logger.
- **Dependable:** Alarm out on echo loss so user knows when the unit is operational.
- **Low maintenance:** Self-diagnostic for functionality & remotely reprogrammable.
- **Flexible operating range:** Unit can cover 300 mm to 2.5 m or 900 mm to 5 m.
- **Long term monitoring:** 5+ years' sensor battery life.
- **Fully waterproof:** Unit is rated IP68 making it water proof when submerged.
- **Superior system connectivity:** Second channel enables connection to other devices.
- **Simple installation:** Multiple pre-set options in software, including automatic level/flow conversion.
- **Adapted for ATEX:** Explosion proof sensor with non ATEX option also available.
- **Remotely programmable:** Control through Intelligens data logger.
- **Accurate:** Temperature compensation removes impact of environmental factors on measurement.
- **Flexible:** Multiple alarm thresholds allow for monitoring of water level at a variety of heights.

Applications

The sensor capabilities of the SonicSens make it a standard sensor in many different applications.

As a primary sensor SonicSens monitors the level within a water channel, where its accuracy and dependability make it ideally suited.

It is also highly useful as a secondary sensor in flow monitoring applications, where this output is combined with velocity to generate flow information.

Installation environments for the product include combined sewer overflow surveying, flood prediction and Inflow & Infiltration studies.

MONITORING ASSETS, DELIVERING DATA, BRINGING CONTROL

Sonic Sens

Ultrasonic Sensor

Logger Features

Rating	ATEX/IEC certified to Zone 0
Memory	Up to 2 million readings
Firmware	Safe field / local and remote upgradable Firmware
Sampling rate	Variable sample rate 1s to 24hrs, accelerating on alarm.
Alarms logger ID	Multiple Lower/Upper Limit, Min Flow, Rate Of Change, Channel Difference, In/Out of Band alarm types. Accelerated dial-in on alarm.
Clock	On board 24 hour synchronized real time clock with date facility
Secondary channel	Log fast data, average minimum, average maximum or event duration
Dimensions (mm)	200H x 97W x 88D
Weight	1kg
Operating temp	-20°C to +60°C (-5°F to +140°F)
Ingress protection	IP68
Power	User Replaceable battery pack operational for 5 years + under standard operating conditions, complete with low battery alarm. External Power optional available with a suitable ATEX certified power source
External power input	External battery pack for non-ATEX applications.

Communication

Internal cellular modem	GPRS to HWM DataGate or customer specific server. SMS Backup Quad band modem Optional 3G Frequent Dial-In Available
Accelerated dial In	Dial-in rate is increased if alarm situation is triggered. Logger can accelerate dial-in at alarm level for multiple applications – including SonicSens, Flow, Pressure, and other alarmed sensors.

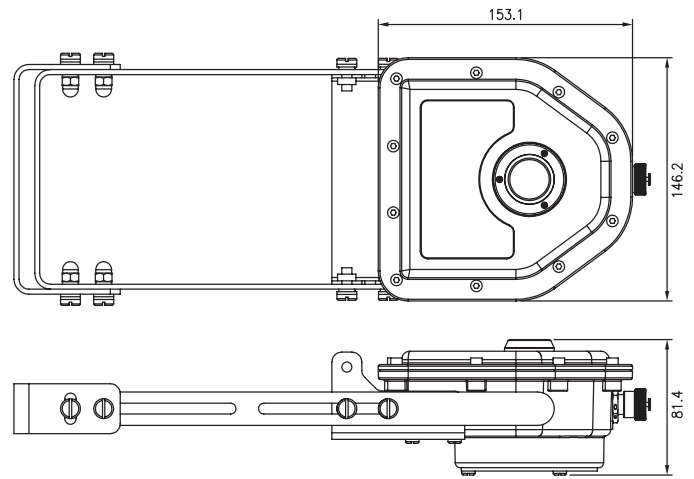

Sensor Input

mV	Example: Pressure sensor for level measurement
Serial Digital Interface	Example: Conductivity measurement
4- 20 mA	Example: Mems tilt transmitter, radar sensor
Digital	Example: Float switch, rain gauge

Ultrasonic Sensor

Ultrasonic Measurement	Measurement Range: 300mm to 2.5m or 900mm to 5m. For higher ranges, please enquire to your HWM representative. Resolution 1 mm (1/25"). Built in temperature compensation Accuracy in air 0.25% of target range Beam Angle 10 deg at -3dB boundary Ultrasonic echo processing. Operating temperature -20 to +60°C (-5 to +140°F) Average power consumption 100 micro Amps at 5 minute sample rate
Construction	Potted ABS plastic enclosure, IP68 submersible
Dimensions/ Weight	Box Size: 140L x 80W x 67D mm (5.5"L x 3.1"W x 2.6"Deep) Aluminum adjustable bracket 170 to 210mm (sensor to side mount) Sensor weight, including bracket: 1.3 Kg (2.8 lb)
Connection	Serial communications and power from logger via single cable fitted with 4 pin Military connector



All Images, text and designs are protected by international and UK copy write law, and remain the property of HWM. It is against the law to copy or use any of the content from HWM website or literature without the written consent of HWM. HWM Ltd. reserve the right to vary the specification. **Issue 1.**

Allied Power Technology Limited

Unit B, 11/F Long To Building
654-656 Castle Peak Road
Lai Chi Kok, Kowloon, Hong Kong

Tel: +852 3746 9033
Fax: +852 852 2120 8765
Email: contact@alliedpower.com.hk

MONITORING ASSETS, DELIVERING DATA, BRINGING CONTROL

www.alliedpower.com.hk

Allied Power
We Empower Your Business

奥
华